

# Sprocket Alignment

## Practice for Aligning Sprockets

- Sprockets should be replaced and aligned whenever new chains are installed. This will have a significant effect on chain life.
- Particular care should be paid to ensure that the shafts are installed parallel and that sprockets are aligned. Both can be accomplished quickly with a laser alignment tool.
- Maximum misalignment for slow moving application (under 10 ft/sec) is 0.2% of the center distance. For faster moving running drives, misalignment should not exceed 0.1% of the center distance.

## Identifying misalignment

Where the misalignment exceeds the specified value or if there is no support in the case of vertical chain drives, the following can be observed.

- The inner links of the chain will interfere with the sprocket teeth resulting in continuous knocking of the inner link plates, which are eventually pushed outwards until they contact the outer link plates and reduce the freedom of movement.
- Vibration will also be observed which will further accelerate the wear of both chain and sprockets.

## Examples of misalignment

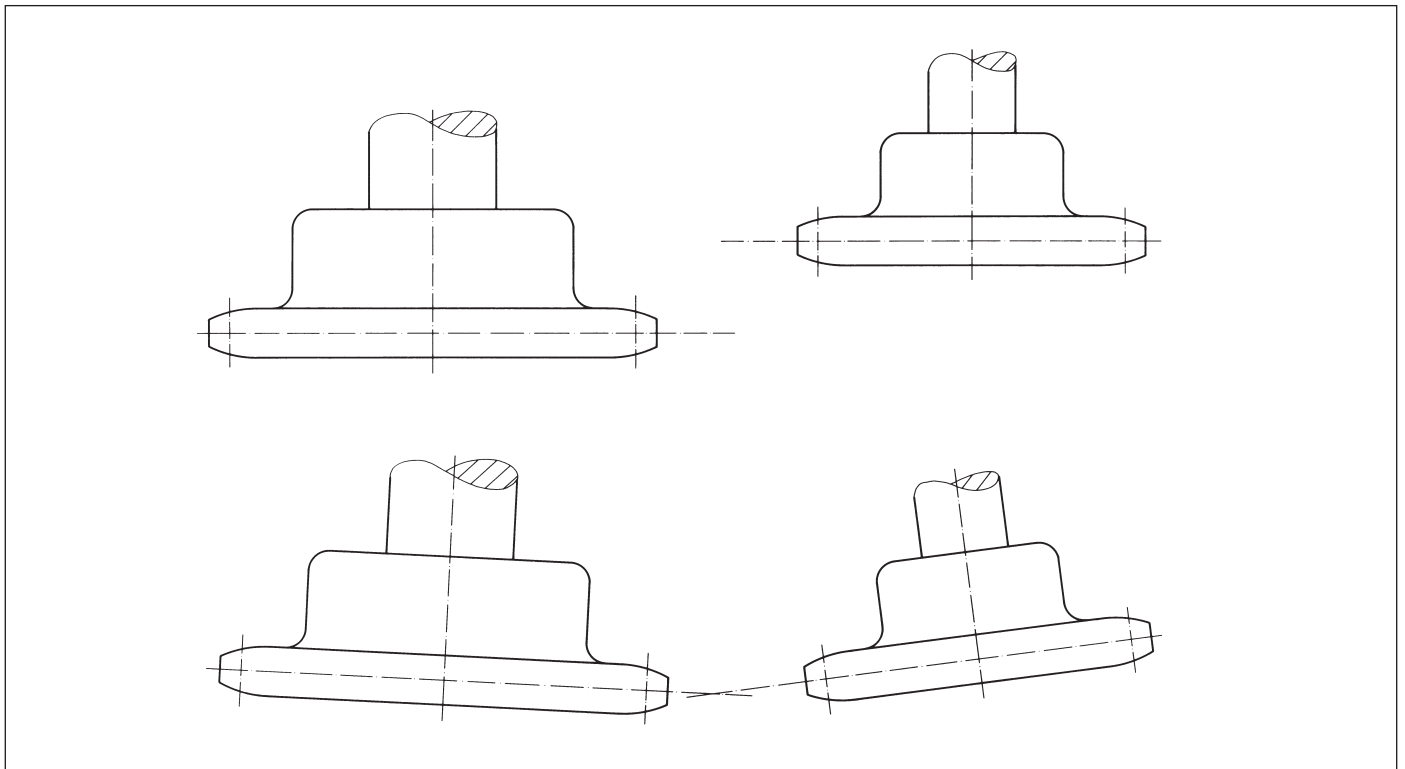

### For more information, contact us:

**iwis drive systems LLC** / Building 100, 8266 Zionsville Road, Indianapolis, IN 46268 USA  
Phone 317 821-3539 / Fax 317 821-3569 / sales@iwisusa.com / www.iwisusa.com

[www.iwisusa.com](http://www.iwisusa.com)